

ATHENA SERIES

HEIGHT ADJUSTABLE ELECTRIC BASES

 **Heartwood**[®]
manufacturing ltd + office furniture

Designed to move with you!

**2LEG &
3LEG
MODELS**

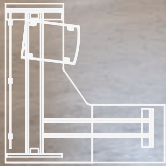

Shown: ATH-E1-3LEG with Silver Finish (SL)
CAL-CM2436-7230 with CAL-2436TOP in Grey Dusk (GD)

Black (BL)

Silver (SL)

**Available
Finishes**

Features:

- Quick assembly design
- Sturdy, 2-stage steel frame construction
- 4 programmable memory positions
- Actuator system with a dual synchronized motor driving each leg
- Includes adjustable glides
- Low power consumption in standby mode
- Flexibility - designed to work with **Calypso Tops** (sold separately) or retrofit an existing top to this unit
- Fits 24" & 30" tops, centered legs for more support
- 2 Leg model easily converts to a 3 Leg model with the addition of leg component add-on



Extended Height Range:
27.5" - 45.5" (does not include top)

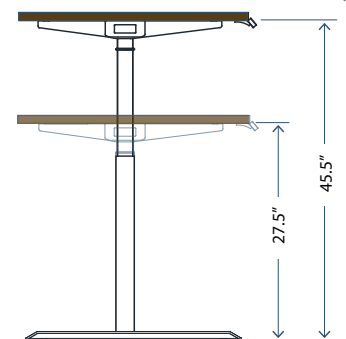

Width Adjustment:

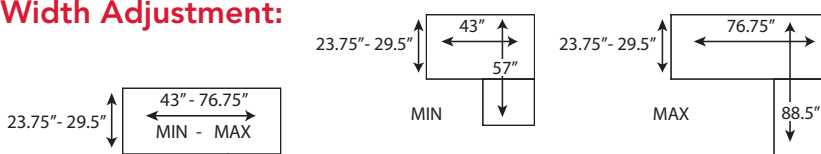

www.heartwood.ca

Technical Specifications:

- Foot depth is 23" - suitable for 24" - 30" deep tops
- Anti-collision function - stops automatically if it hits an immovable object
- Actuator system with a synchronized motor driving each leg
- Operated at 1" per second
- Whisper quiet <50dB
- Lifting Capacity: 2-LEG - 220lbs
 3-LEG - 330lbs
- CSA/UL Certified
- ATH-E1-2LEG is BIFMA Certified (ANSI/BIFMA x 5.5-2014)
- Compatible with desking accessories (9" Accessory clearance depth on a 30" top)

Optional Caster

900-CASTER-M8-MB

- Sold quantity 2 casters
- 2 leg base - 2 set required
- 3 leg base - 3 sets required
- Durable PVC material
- Safe for use on soft or hard floors
- M8 threaded stem caster
- Maximum weight 32kg/66lbs per caster



monitor arms



keyboard tray



wire management snake

Height Adjustable Bases

Model:

ATH-E1-2LEG

ATH-E1-3LEG

(TOPS SOLD SEPARATELY)

Description:

STRAIGHT DESK

L SHAPE DESK

Calypso Tops

- Available in all Heartwood finishes recommended for worksurface applications including solid colour and woodgrains.
- Edges have durable matching banding. Alternates to default banding finish are available at no extra charge.
- 1" or 1½" thick tops available, 1½" are fluted by default.
- Rectangle tops, corner module tops (including radius corner module shape) & return tops (do not have grommets) are available
- Custom sizing available - Calypso Tops are customizable and **Made-to-Fit**
- See price book for a complete list of sizes and SKUs

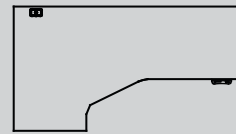

DEFAULT - CM SHAPE



RCM SHAPE

FOR RADIUS CORNER MODULE SHAPE, ADD "R" TO SKU
ORDER EXAMPLE: CAL-RCM2436-7224



 **Heartwood**[®]
manufacturing ltd  office furniture
251 Adams Rd, Kelowna, BC V1X 7R1
T: 1 800 567 3060
F: 250 765 1213

Contact your local dealer:

www.heartwood.ca